

# Instruction Sheet 产品说明书

PA-31840

Oct. 2018 / 2018 年 10 月

## DX3 Electronic Expansion Valve

## DX3 电子膨胀阀

### Overall Dimension (mm) 总体尺寸 (mm)

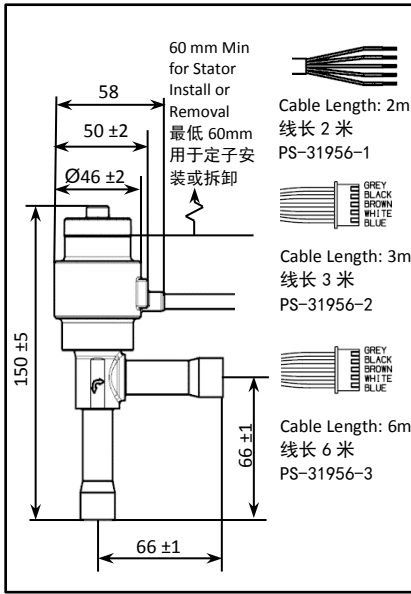

### Wiring Detail 接线详图

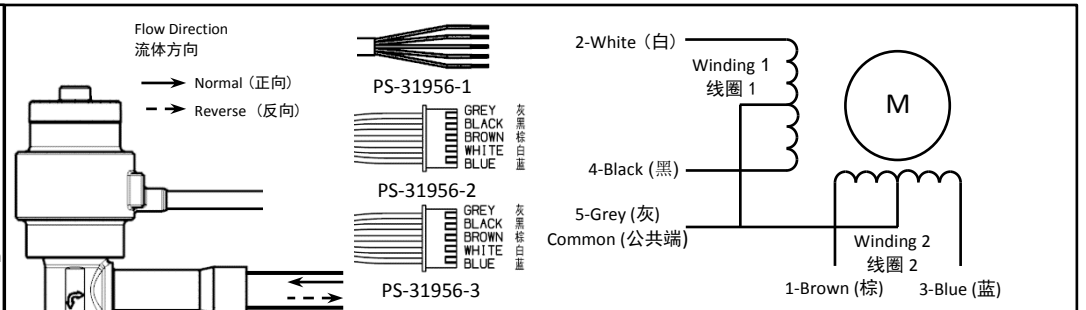

### Excitation way and valve-on and valve-off connection graph 励磁方式与开关阀对应关系图

Wire No. & Color (线号及颜色)	Valve Movement (阀芯运动)							
	→ Open (开启方向)				← Close (关闭方向)			
	ON	ON	OFF	OFF	OFF	OFF	ON	ON
2 - White (白)	ON	ON	OFF	OFF	OFF	OFF	ON	ON
4 - Black (黑)	OFF	OFF	OFF	ON	ON	ON	OFF	OFF
1 - Brown (棕)	OFF	ON	ON	ON	OFF	OFF	OFF	OFF
3 - Blue (蓝)	OFF	OFF	OFF	OFF	OFF	ON	ON	ON
5 - Grey (灰)	ON	ON	ON	ON	ON	ON	ON	ON

### Mounting Sequence (安装顺序)

#### 1. Valve Position (阀安装位置)

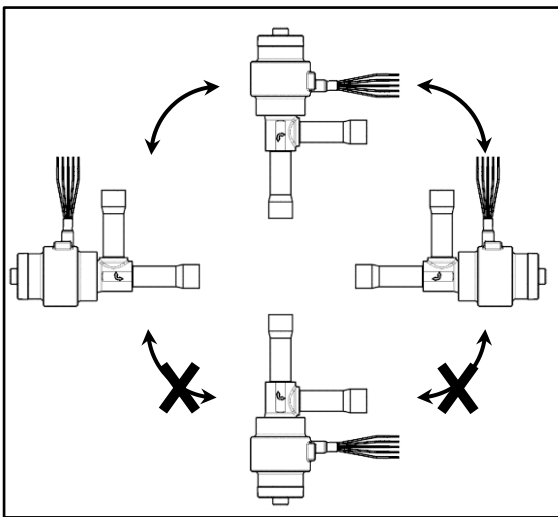

#### 2. Welding (焊接)

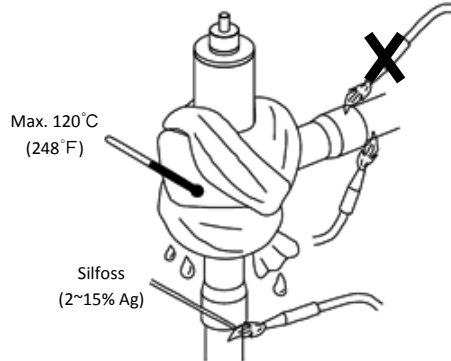

#### 3. Stator Mounting (定子安装)

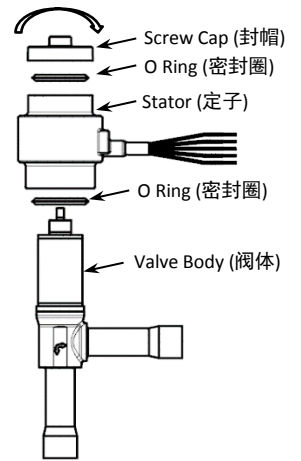

#### 5. Thermal Insulation Material Enveloping (隔热材料包裹)

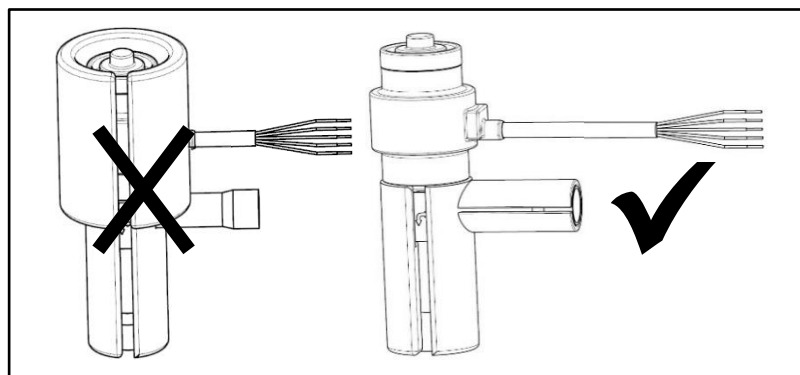

#### 4. Controller Connection (连接控制器)

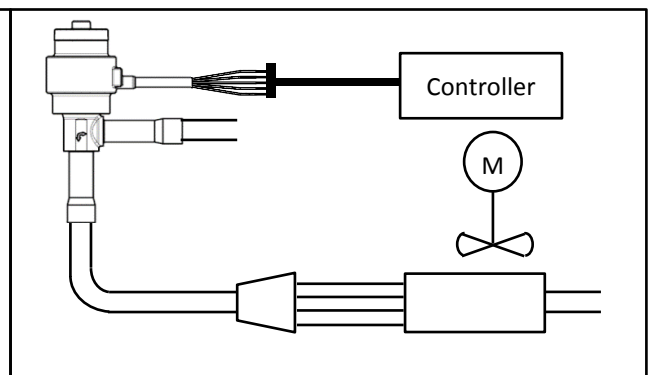

**CAUTION**

1. Read mounting instructions thoroughly. Failure to comply can result in device failure, system damage or personal injury.
1. 安装前仔细阅读安装说明，任何不按指导规范的操作可能会造成设备失效、系统损坏或者人员伤害。
2. Mounting and wiring should follow these instructions.
2. 安装及接线需要按照上述指导说明。
3. Valve mounting, electrical wiring, and service and maintenance work should be performed by qualified persons having the appropriate knowledge and skill.
3. 阀安装、电气接线以及维保需要由掌握正确知识技能并有相关资质的人员进行。
4. Comply with local electrical regulations when wiring.
4. 接线时需遵从当地电气规范。
5. Do not excite the stator before mounting it to the valve. Do not operate system before all cable connections are completed.
5. 在将定子正确安装前，不要激励定子。调试完成前，不要开启系统。
6. Before attempting to mount valve, make sure pressure in system is brought to and remains at atmospheric pressure.
6. 安装阀前，确认系统保持大气压。
7. Do not disassemble the valve during brazing.
7. 焊接时不得拆解阀。
8. Stator must be fixed tightly after screwing the screw cap into valve.
8. 将封帽拧紧后，定子应牢固固定。
9. Do not release refrigerant into atmosphere.
9. 不要将制冷剂排放至大气中。

**Mounting position:**

**安装位置:**

- Valve must be mounted in horizontal position to vertical position, but cannot be placed upside down (Mounting sequence figure 1). For best results, locate valve as close as possible to distributor or inlet of evaporator.
- 阀需在水平至垂直方向间安装，但阀不允许倒装（安装顺序图1）。为了精确控制，阀应尽可能靠近分液器或者蒸发器入口。

**Brazing (Mounting Sequence 2) (Very important, read carefully, and comply with instructions):**

**焊接: (安装顺序图 2) (非常重要, 请仔细阅读并按要求操作)**

- Do not place brazing flame on or near valve, use saturated wet rags or other thermal insulation method to ensure max. body temperature not exceeding 120°C (248°F), no water vapor into valve is allowed;
- 焊接时焊焰需远离阀体，使用包裹湿布或其它隔热方法，保证阀体表面低于120°C (248°F)，不得让水气进入阀体内；
- To avoid oxidization, it is advised to purge system with an inert gas such as nitrogen while brazing;
- 焊接时，为防止内部产生氧化物，请使用充氮或其它惰性气体保护；
- Never braze valve unless it keeps factory settings (Valve is fully opened);
- 阀处于出厂状态(阀全开)时，才能焊接阀体；
- Brazing flame should not be facing the valve.
- 焊接时焊焰方向应背向阀体，不得朝向阀体。

**Controller connection (Mounting Sequence 4):**

**控制器连接: (安装顺序图 4)**

- Original length of control cable is 2m, wiring refers to “excitation way and valve-on and valve-off connection graph”, extending cable is allowed when longer cable is needed in field, extending cable cannot be longer than 6m (including original cable with length of 2m), extending cable type is UL2464 0.34mm2, temperature rating is -25~+80°C, and if valve is used in a mobile condition (such as vehicle), temperature variation should be taken into consideration in cable selection.
- 控制线初始线长为2米，接线参考接线详图中的励磁方式与开关阀对应图，当现场需要更长控制线时，可对其进行扩展，扩展线长不超过6米（含初始2米控制线），扩展线规格为UL2464 0.34mm2，温度范围为-25~+80°C。如在移动环境中（如汽车）使用阀，扩展线缆选择时需考虑温度变化的影响。
- Optional length of control cable is 3m/6m with terminal, terminal connection refers to “excitation way and valve-on and valve-off connection graph”.
- 可选的控制线长为带端子3米/6米，端子接线参考接线详图中的励磁方式与开关阀对应图。

**Thermal insulation material enveloping (Mounting Sequence 5):**

**隔热材料包裹: (安装顺序图 5)**

Do not envelope thermal insulation material on stator after valve mounting to ensure heat dissipation. 为保证电机散热性能，阀安装完毕后定子上不得包裹隔热材料。

**Warning:**

**警告:**

All valves are fully opened, do not charge refrigerant until valve is fully closed. 所有的阀在出厂时均处于全开状态，在阀完全关闭前不得对系统充注制冷剂。



**Names and Contents of the Hazardous Substances in Product**  
产品中有毒物质名称及含量

Part Name 部件名称	有害物质 (Hazardous Substance)					
	Pb (铅)	Hg (汞)	Cd (镉)	Cr +6 (六价铬)	PBB (多溴联苯)	PBDE (多溴二苯醚)
Copper And Alloys of Copper (铜及铜合金)	X	0	0	0	0	0
Steel And Stainless Steel Parts (钢及不锈钢件)	0	0	0	0	0	0
Plastic Parts (塑料件)	0	0	0	0	0	0
Rubber Parts (橡胶件)	0	0	0	0	0	0
Magnetic Materials (磁性材料)	0	0	0	0	0	0

This table is prepared in accordance with the provision of SJ/T 11364.  
本表格依据 SJ/T 11364 的规定编制。  
O: Indicate that said hazardous substance contained in all of the homogeneous materials for this part does not exceed the limit requirement of GB/T 26572  
O: 表示该有害物质在该部件所有均质材料中的含量均不超出 GB/T 26572 规定的限量要求  
X: Indicate that said hazardous substance contained in at least one of the homogeneous materials used for this parts is above the limit requirement of GB/T 26572  
X: 表示该有害物质至少在该部件的某一均质材料中的含量超出 GB/T 26572 规定的限量要求

Technical data are correct at the time of printing. Updates may occur, and should you need confirmation of a specific value, please contact Emerson clearly stating the information required.

Emerson cannot be held responsible for errors in capacities, dimensions, etc., stated herein. Products, specifications and data in this literature are subject to change without notice. The information given herein is based on data and tests which Emerson believes to be reliable and which are in accordance with today's technical knowledge. It is intended for use by persons having the appropriate technical knowledge and skill, at their own discretion and risk.

技术数据在印刷前已经校对过，印刷之后有再更新的可能，如有需要对某一参数确认，请联系艾默生环境优化技术。

艾默生环境优化技术对参数中可能存在的差错概不负责，艾默生环境优化技术保留自行改变其产品而不预先通知的权利。

本文件中的参数基于艾默生环境优化技术认为可靠的数据和测试，并符合今天的技术需求。这些信息预期由具有合适的专业知识和技能的人员自行判断和评估风险后来使用。